

## ELECTRIC GAS PREHEATER type EP

11/2023

### 1. APPLICATION

The electric gas preheater is designed for heating natural gas (with a high methane content and hydrogen content of up to 25% by volume) in technological equipment, for example, gas pressure regulating stations according to EN 12186. The working fluid can be natural gas, natural gas and hydrogen mixture ( $H_2$  content is limited to 25% [volume]). Direct contact between gas and heating rods causes heat transmission.

The preheater meets the technical requirements for gas-preheating equipment according to EN 12186. The design of the preheater meets the provisions of EN 60079-0, EN 60079-1 and EN 60079-15.

The electric preheater is equipment group IIA acc. to EN 60079-0 and the preheater is intended for working in potentially explosive atmospheres, Zone 2 acc. to EN 60079-10-1. The preheater is certified by notified body acc. to Directive 2014/34/EU (ATEX).

The electric preheater is pressure equipment within the meaning of Directive 2014/68/EU and the preheater is certified by a notified body. The design calculation is according to EN 13445.

### 2. DESCRIPTION

The preheater consists of a tubular body equipped with flange branches for gas inlet and outlet.

The upper part of the preheater forms a flameproof enclosure for the electrical terminal board (protection type "db"). Resistance heating rods are fixed and sealed in the lower cover of the flameproof enclosure, and the rods extend into the tubular body. Parts on the preheater body:

1. welded-on piece with a pocket for placing the thermostat in a flameproof enclosure (protection type "db"),
2. surface temperature circuit-breaker formed by a thermal fuse in a cover with protection type "nA",
3. welded-on piece for a pocket for an indicating thermometer or temperature sensor Pt100.

Disconnection of heating rods from the supply by a thermostat or thermal fuse must be done indirectly using a protective electrical device which is not part of the preheater.

Such a device must be independent of a system that serves for preheater temperature regulation.



Technical parameters	EP 06			EP 12			EP 18		
Electric input	6 kW			12 kW			18 kW		
Supply voltage/current	3 x 400 V / 9 A			3 x 400 V / 18 A			3 x 400 V / 27 A		
Specific marking of the preheater	 II 3 G Ex db nA IIA T3 Gc								
Degree of protection	IP 54								
Working environment	Zone 2 according to EN 60079-10-1								
Calculation temperature	+ 200 °C								
Working temperature of wall	- 20 to + 50 °C								
Ambient temperature range	- 20 to + 50 °C								
Nominal gas pressure PN	40	63	100	40	63	40	63	100	
Max. allowable pressure	40 bar	63 bar	100 bar	40 bar	63 bar	40 bar	63 bar	100 bar	

Technical parameters		EP 06					EP 12				EP 18						
Electric input		6 kW					12 kW				18 kW						
Nominal gas pressure PN		40		63		100		40		63		40		63		100	
Inlet and outlet flange		DN 25	DN 50	DN 25	DN 50	DN 25	DN 50	DN 80	DN 25	DN 50	DN 50	DN 80	DN 25	DN 50	DN 25	DN 50	
Max. gas flow * for $v_{max}=35$ m/s		50 m <sup>3</sup> /h	220 m <sup>3</sup> /h	45 m <sup>3</sup> /h	190 m <sup>3</sup> /h	45 m <sup>3</sup> /h	220 m <sup>3</sup> /h	520 m <sup>3</sup> /h	45 m <sup>3</sup> /h	190 m <sup>3</sup> /h	220 m <sup>3</sup> /h	520 m <sup>3</sup> /h	45 m <sup>3</sup> /h	190 m <sup>3</sup> /h	45 m <sup>3</sup> /h	190 m <sup>3</sup> /h	
Weight (acc. to version)		~ 80 kg	~ 85 kg	~ 105 kg	~ 110 kg	~ 170 kg	~ 130 kg	~ 135 kg	~ 180 kg	~ 185 kg	~ 170 kg	~ 175 kg	~ 245 kg	~ 250 kg	~ 390 kg	~ 395 kg	
Terminal board	Flameproof enclosure of terminal board	Ex db IIA T3															
	Ø supply cable	10 ÷ 16 mm															
Thermostat	Max. capacity of thermostat contacts	250 V / 15 A ~															
	Flameproof enclosure of thermostat	Ex db IIA T3															
	Fixed setting of thermostat switching off temperature depending on PN	30 °C for PN 40		50 °C for PN 63 and PN 100			30 °C for PN 40		50 °C for PN 63		30 °C for PN 40		50 °C for PN 63 and PN 100				
	Ø thermostat supply cable	4,5 ÷ 8,5 mm															
Fuse	Fuse nominal voltage/current	250 V / 10 A ~															
	Thermal fuse – Ex	Ex nA IIA T3															
	Nominal releasing temperature of fuse	93 °C															
	Ø fuse supply cable	4,5 ÷ 8,5 mm															

\* it is recommended  $v_{max}=20 \div 25$  m/s

### The type number is determined as follows:

**EP 06 040 50 A C**

#### Flanges:

A - flanges ANSI B16.5 / 600 lbs / RF

B - flanges ANSI B16.5 / 300 lbs / RF

C - flanges EN 1092-1:

PN 40 – sealing rod type B1

PN 63, PN 100 – sealing rod type B2

#### Version:

A - direct, left inlet, right outlet

B - direct, right inlet, left outlet

C - inlet from below, right outlet

D - inlet from below, left outlet

E - inlet from behind, right outlet

F - inlet from behind, left outlet

G – direct, left inlet, left outlet

H – direct, right inlet, right outlet

J – angular, left inlet, outlet to the back

K – angular, right inlet, outlet to the back

#### Inlet and outlet flange:

25 - DN 25

50 - DN 50

80 - DN 80

#### Nominal gas pressure:

040 - PN 40

063 - PN 63

100 - PN 100

#### Installed electric input:

06 – installed electric input 6 kW

12 – installed electric input 12 kW

18 – installed electric input 18 kW

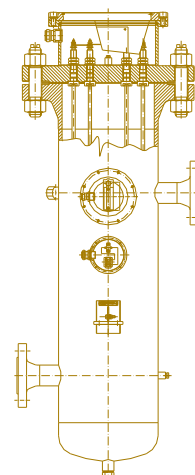

VERSION: EP 06 xxx xxxx  
 EP 12 xxx xxxx  
 EP 18 040 xxxx  
 EP 18 063 xxxx

VERSION: EP 18 100 xxxx

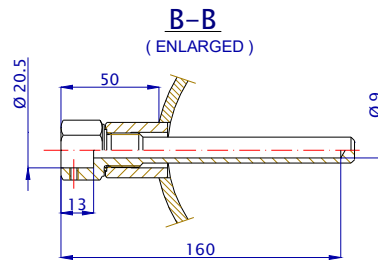
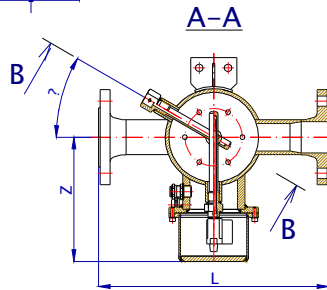
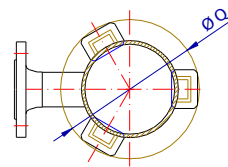
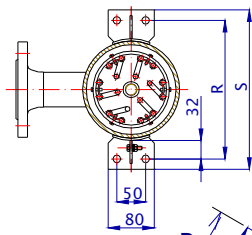
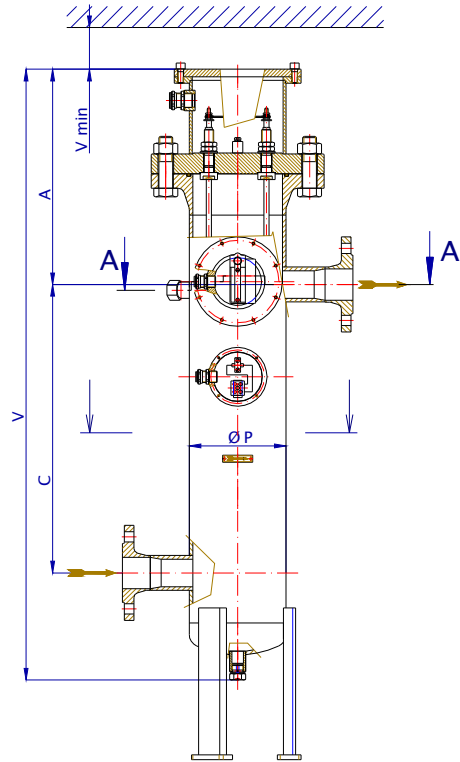
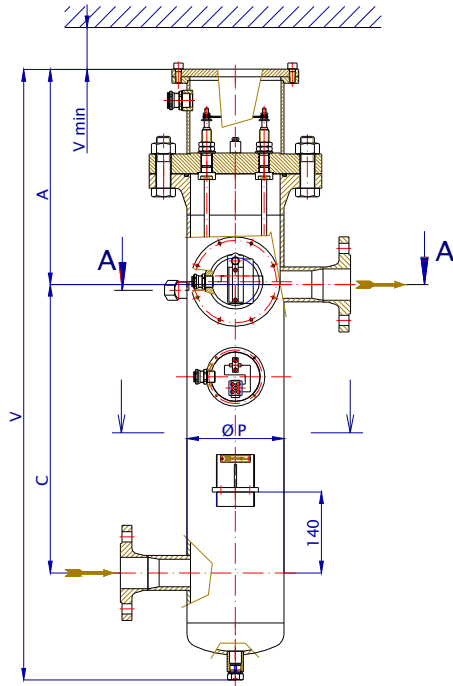

Dimensions of basic type EP 06, EP 12 and EP 18 for pressure PN 40

VERSION	DN	PN	A	C	G	H	L	øP	øQ	R	S	α	V	V <sub>1</sub>	V <sub>min</sub>	V <sub>dem</sub>	Z
EP 06 040 25 _C	25	40	380	500	-	750	350	168	-	240	276	30°	1070	1130	400	880	215
EP 06 040 50 _C	50	40	380	500	-	750	400	168	-	240	276	30°	1070	1130	400	880	215
EP 06 040 25 _A	1"	40	380	500	-	750	400	168	-	240	276	30°	1070	1130	400	880	215
EP 06 040 50 _A	2"	40	380	500	-	750	450	168	-	240	276	30°	1070	1130	400	880	215
EP 12 040 50 _C	50	40	380	500	-	800	500	219	-	294	330	30°	1125	1180	400	880	240
EP 12 040 80 _C	80	40	380	500	-	800	500	219	-	294	330	30°	1125	1180	400	880	240
EP 12 040 50 _A	2"	40	380	500	-	850	500	219	-	294	330	30°	1125	1230	400	880	240
EP 12 040 80 _A	3"	40	380	500	-	850	500	219	-	294	330	30°	1125	1230	400	880	240
EP 18 040 50 _C	50	40	410	500	-	800	500	273	-	350	386	30°	1180	1210	400	880	270
EP 18 040 80 _C	80	40	410	500	-	800	500	273	-	350	386	30°	1180	1210	400	880	270
EP 18 040 50 _A	2"	40	410	500	-	800	550	273	-	350	386	30°	1180	1260	400	880	270
EP 18 040 80 _A	3"	40	410	500	-	800	550	273	-	350	386	30°	1180	1260	400	880	270

## VERSION

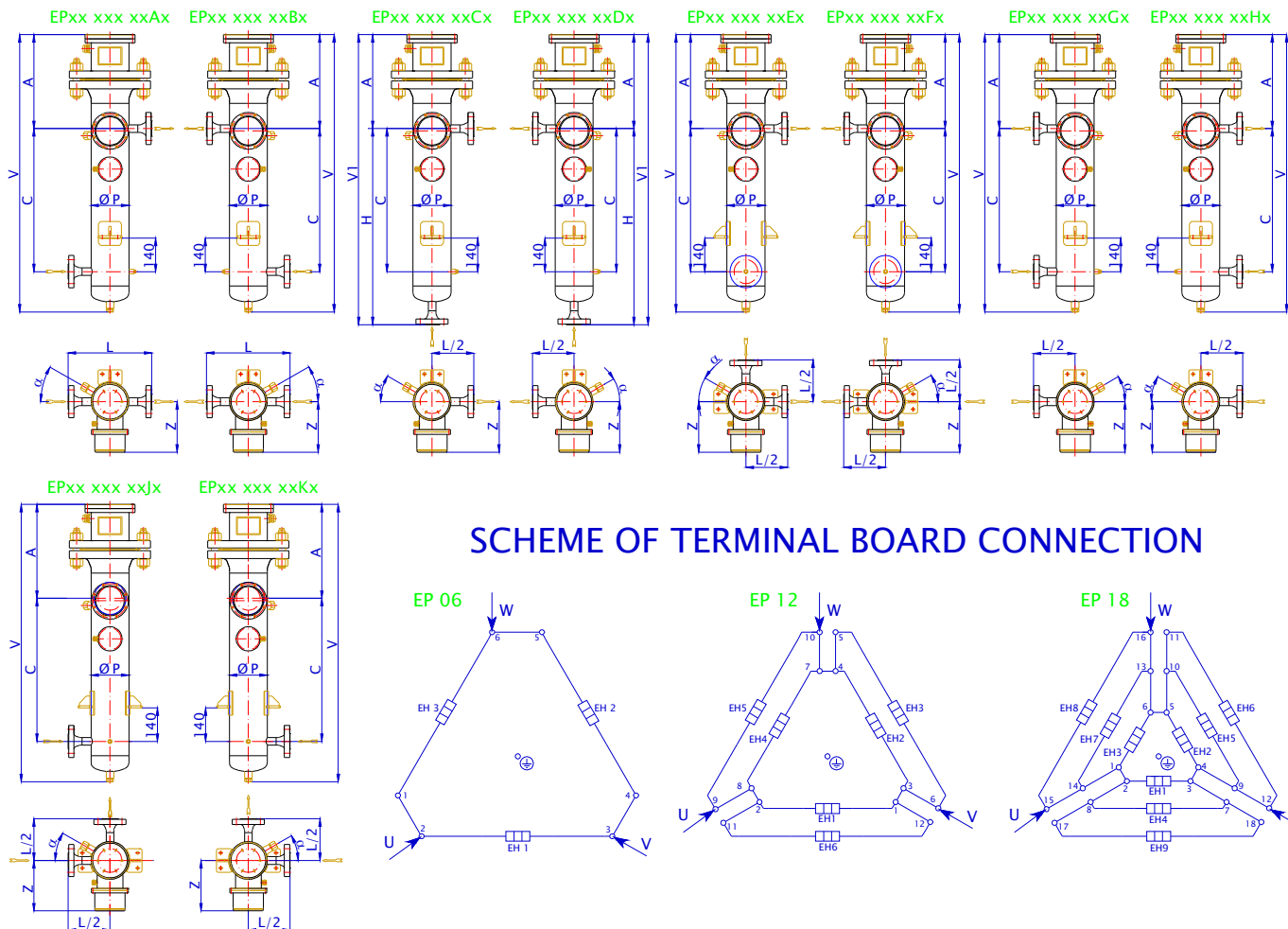

**Dimensions of basic type EP 06, EP 12 and EP 18 for pressure PN 63**

VERSION	DN	PN	A	C	G	H	L	øP	øQ	R	S	α	V	V <sub>1</sub>	V <sub>min</sub>	V <sub>dem</sub>	Z
EP 06 063 25 _C	25	63	395	600	-	800	350	168	-	240	276	30°	1165	1195	400	950	215
EP 06 063 50 _C	50	63	395	600	-	800	400	168	-	240	276	30°	1165	1195	400	950	215
EP 06 063 25 _A	1"	63	395	600	-	800	400	168	-	240	276	30°	1165	1195	400	950	215
EP 06 063 50 _A	2"	63	395	600	-	800	450	168	-	240	276	30°	1165	1195	400	950	215
EP 12 063 25 _C	25	63	395	600	-	900	500	219	-	294	330	30°	1225	1295	400	950	240
EP 12 063 50 _C	50	63	395	600	-	900	500	219	-	294	330	30°	1225	1295	400	950	240
EP 12 063 25 _A	1"	63	395	600	-	950	500	219	-	294	330	30°	1225	1345	400	950	240
EP 12 063 50 _A	2"	63	395	600	-	950	500	219	-	294	330	30°	1225	1345	400	950	240
EP 18 063 25 _C	25	63	495	500	-	850	500	273	-	350	386	30°	1275	1345	400	950	270
EP 18 063 50 _C	50	63	495	500	-	850	500	273	-	350	386	30°	1275	1345	400	950	270
EP 18 063 25 _A	1"	63	495	500	-	850	500	273	-	350	386	30°	1275	1345	400	950	270
EP 18 063 50 _A	2"	63	495	500	-	850	500	273	-	350	386	30°	1275	1345	400	950	270

**Dimensions of basic type EP 06 and EP 18 for pressure PN 100**

VERSION	DN	PN	A	C	G	H	L	øP	øQ	R	S	α	V	V <sub>1</sub>	V <sub>min</sub>	V <sub>dem</sub>	Z
EP 06 100 25 _C	25	100	420	600	-	800	350	168	-	240	276	30°	1240	1220	400	950	215
EP 06 100 25 _A	1"	100	420	600	-	800	400	168	-	240	276	30°	1240	1220	400	950	215
EP 18 100 25 _C	25	100	520	500	600	900	500	273	380	-	-	30°	1300	1420	400	980	270
EP 18 100 50 _C	50	100	520	500	600	900	500	273	380	-	-	30°	1300	1420	400	980	270
EP 18 100 25 _A	1"	100	520	500	600	900	500	273	380	-	-	30°	1300	1420	400	980	270
EP 18 100 50 _A	2"	100	520	500	600	900	500	273	380	-	-	30°	1300	1420	400	980	270

Note: After " \_ " comes the letter ( A + K ) indicating the location of the inlet and outlet flange.  
Detailed data about gas electric preheater EP are given i document TPN, can be sent on your request.